



BONDING AND GROUNDING AMP NETCONNECT COPPER CABLING SYSTEMS

*A Complete Review of Bonding and Grounding for Copper
Twisted-pair Cabling Systems*



Table of Contents

INTRODUCTION.....	3
GROUNDING AND BONDING BASICS	3
BONDING STP & UTP TELECOMMUNICATIONS SYSTEMS.....	3
STRAIGHTFORWARD ANSWERS TO STP	6
GROUNDING & BONDING IN THE TR.....	6
GROUNDING & BONDING AT THE WORKSTATION.....	6
TESTING FOR GROUND LOOPS AND PROPER GROUNDING & BONDING.....	8
SUMMARY	8

INTRODUCTION

Grounding and bonding is the single most important practice for the protection of people and property. The National Electric Code (NEC), NFPA 70, defines grounding and bonding and provides requirements for the grounding of a building's electrical system. In our industry, the *TIA J-STD-607-A Commercial Building Grounding (Earthing) and Bonding Requirements for Telecommunications* is designed to enable the planning, design, and installation of a telecommunications grounding and bonding system.

One of the biggest myths in the telecommunications industry involves the grounding and bonding of shielded twisted-pair (STP) copper cabling systems. Throughout the industry, there is a misconception that grounding and bonding of STP systems is more difficult, more time consuming, and more technique sensitive. This is simply not true. In this white paper, you will learn how to properly ground and bond an STP copper cabling system, and you will see that it is straightforward and essentially no different than grounding and bonding a UTP system.

GROUNDING AND BONDING BASICS

You know that grounding and bonding is absolutely necessary, but what exactly is grounding and what is bonding? Let's start with the definitions according to the NEC:

- **Grounding:** Establishing a connection, whether intentional or accidental, between an electrical circuit or equipment and the earth or to some conducting body that serves in place of the earth.
- **Bonding:** The permanent joining of metallic parts to form an electrically conductive path that ensures electrical continuity and the capacity to conduct safely any current likely to be imposed.

Let's clarify those definitions further. Grounding provides a path for surges in the power systems, conducting electrical energy to earth to prevent arcing, heating, or explosion during a lightning strike. It is fundamental to understand that only a proper grounding system can prevent harm from such events.

The primary purpose of bonding is to equalize ground potential and eliminate static discharge between components and equipment. When a potential difference exists between two metallic components joined by a conductor like cable, electrons flow from one component to the other in attempts to equalize the two components. When this happens, the electrons can damage any equipment in its path. Proper bonding, or achieving a common ground potential, reduces the likelihood of electrical shock, equipment damage, and data contamination from voltage and current noise.

Within a building, there is one common ground for all electrical systems, which the NEC refers to as the grounding electrode system. According to the NEC, the grounding electrode system is the responsibility of the electrical contractor, and the telecommunications installer NEVER actually installs a grounding system unless he or she is also a licensed electrical installer. However, the telecommunications contractor is required to bond the components of the telecommunications system and bond the entire system to a suitable ground point.

BONDING STP & UTP TELECOMMUNICATIONS SYSTEMS

Not only is grounding and bonding important for the protection of the people and property, proper bonding of the telecommunications system per the current TIA J-STD-607-A standard is also vital to ensure reliable data transmission performance. Proper bonding is necessary to ensure that the effects of unwanted noise signals (antenna effect) on telecommunications cables do not interfere with the overall network performance. Grounding and bonding is also a life safety issue since metallic parts may become accidentally energized, causing an electrical hazard.

First and foremost, it's imperative to understand that the following bonding requirements of a telecommunications system are applicable to **both STP and UTP systems**. It doesn't matter which type of system you're installing! To bond all the components of the telecommunications infrastructure, the current TIA J-STD-607-A requires the following (see Figure 1):

- **Telecommunications main grounding busbar (TMGB):** The TMGB is the central attachment point for all components of the telecommunications system's grounding (bonding) infrastructure. Located in the

telecommunications entrance facility (TEF), the TMGB is a predrilled copper busbar with holes for use with standard-sized lugs that must be insulated to ensure it is electrically isolated from the wall or other mounting surface. The standard requires the TMGB to be a minimum of 6.3 mm (0.25 in) thick by 100 mm (4 in) wide and variable in length. The TMGB should be bonded to the building's nearest (within 30') grounding electrode system via the ac main service electrical panelboard located at the TEF. An alternate solution is to attach the bonding conductor to the nearest grounded ac electrical branch circuit panel. For additional redundancy, the TMGB must also be bonded to the nearest ground point, which in most cases is the building's structural steel.

- Telecommunications grounding busbar (TGB): The TGB is the attachment point for all telecommunications systems and equipment in a specific telecommunications space. Therefore, each telecommunications room (TR) throughout the building should have a TGB. Also a predrilled copper busbar with holes for standard sized lugs, the TGB must be at least 6.3 mm (0.25) thick by 50 mm wide (2 in). TGBs must be insulated to ensure they are electrically isolated from the wall or other mounting surface. A bonding connection should always be made to the equipment grounding busbar located in the nearest electrical panel board that supplies the ac electrical power. For additional redundancy, each TGB should also be bonded to the nearest ground point, which in most cases is the building's structural steel. Each TGB should be bonded to the TMGB via the TBB if specified (see below).
- Telecommunications bonding backbone (TBB): The TBB is a 6 AWG or larger grounding (bonding) conductor that bonds all TGBs with the TMGB as part of the telecommunications pathways and spaces (independent of cable). The size of the TBB is dependent on the length, up to a maximum size of 3/0 AWG for lengths greater than 20 meters (66 feet). The TBB is an optional design method. Each TGB should be bonded to the ac electrical panel board servicing that floor with a supplemental bonding connection to the metal frame of the building.
- Grounding Equalizer (GE): Whenever two or more TBBs exist in a multistory building, they must be bonded together with a GE at the top floor and at every third floor in between. The GE is also sized the same as the TBB.
- Bonding conductor for telecommunications (BCT): From the telecommunications entrance facility, the TMGB is bonded to the building's grounding electrode system with the BCT. The BCT is also sized like the TBB and GE at a minimum of 6 AWG.

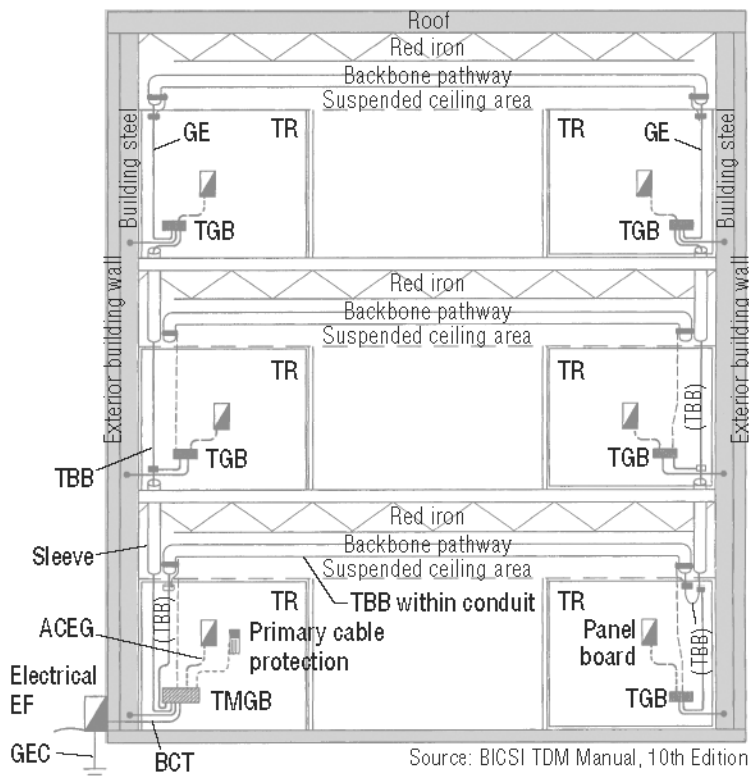

ACEG	= Alternating current equipment ground
BC	= Bonding conductor
BCT	= Bonding conductor for telecommunications
EF	= Entrance facility
ER	= Equipment room
GE	= Grounding equalizer
GEC	= Grounding electrode conductor
TBB	= Telecommunications bonding backbone
TGB	= Telecommunications grounding busbar
TMGB	= Telecommunications main grounding busbar
TR	= Telecommunications room

Figure 1: Bonding and Grounding

There is often confusion about what components of the telecommunications infrastructure should be bonded. To determine what should be bonded, installers need to ask themselves if a metallic component is attached to the telecommunications cabling infrastructure, or if it comes in contact with any other metallic component attached to the infrastructure. If the answer is yes, it must be bonded. That includes the following:

- Racks
- Ladders
- Enclosures
- Equipment like patch panels, routers, and switches
- Surge protection devices
- Metallic cable tray

In each TR, the metallic components are bonded to the TGB with a grounding (bonding) conductor using two-hole lugs. Code requires all clamp and compression connections to be UL 486A listed. When bonding patch panels, racks, and other painted equipment or components to the TGB, a low resistance path is achieved by scraping the paint or other means that will assure a good ground. At Tyco Electronics, we provide a paint piercing star washer with AMP NETCONNECT patch panels to avoid having to scrape paint and to ensure a proper bonding connection.

Once all of the components of the telecommunications infrastructure are properly bonded, the system must be bonded to the building's ground, which provides a connection to the earth. When the telecommunications system is bonded to the building's ground, it is at the same ground potential as other electrical systems in the building. This is achieved by bonding the TMGB and all TGBs to the building's grounding electrode system.

STRAIGHTFORWARD ANSWERS TO STP

STP cable and connectivity has been on the market for many years and have been widely deployed and proven throughout the world. STP has always offered better RFI/EMI immunity, security, and an electrically superior performance. With 10 Gigabit Ethernet over copper now a reality, the performance of STP systems offers significantly more headroom over 10 Gigabit UTP systems. Furthermore, STP offers a smaller cable diameter and better fill ratio, providing higher density and cost savings.

While performance and density prevail for STP, one of the biggest myths surrounding STP is that installation is more time consuming and difficult due to grounding and bonding issues. But grounding and bonding of an STP system is absolutely no different than with UTP. In this section, we will take the guesswork out of grounding and bonding STP systems by providing answers to common questions and setting straight the misconceptions.

GROUNDING & BONDING IN THE TR

Grounding and bonding of STP systems in the TR is done exactly as described in the standard – by bonding the patch panels, racks, and other metallic components to the TGB. Shielded patch panels, jacks, and cable have the grounding and bonding built in. So once the cable is properly terminated to the jack and the jack mounted to the patch panel, the bonding and grounding is complete. **This process is absolutely no different than what is required for UTP systems.** The most common problem with grounding and bonding occurs when the patch panel and racks are not properly bonded to the TGB – and that problem applies to both UTP and STP systems.

GROUNDING & BONDING AT THE WORKSTATION

Many installers question if they are supposed to ground and bond an STP cabling system at both ends –the TR and at the workstation. The answer is much simpler and more straightforward than you might think. ANSI/TIA-568-C.1, *“Commercial Building Telecommunications Cabling Standard,”* describes how this is accomplished. The easiest way to look at grounding and bonding of a system at the workstation is to consider the difference between a permanent link and a channel.

- Permanent Link: A test configuration for a link excluding test cords and patch cords - the permanently installed horizontal cable and connecting hardware from the workstation outlet to the patch panel in the telecommunications room.
- Channel: The end to end transmission path between two points at which application specific equipment is connected - an end-to-end transmission path, which includes the horizontal permanent link, plus patch cords on either end to connect the communications hardware (i.e. switch, laptop, PC).

In a permanent link, the shield is bonded to ground only at the TR end as previously described above. The workstation end of the permanent link is not bonded to ground. This is the same for both UTP and STP systems. In a channel, the bonding of the permanent link shield to ground at the workstation end is accomplished by connecting a SHIELDED patch cord between the outlet and the equipment. This results in a ground condition at both ends of the channel. It's as simple as that! Computers and networking equipment all include shielded jacks where the shield of the jack is bonded to the ground conductor of the electrical cord. Absolutely no special jacks or interface cards are

required. The equipment is grounded through the electrical receptacle, tying both the electrical and telecommunications system to ground. Even if a shielded patch cord is not used, or the workstation equipment is not grounded through the electrical receptacle, the channel is tied to ground back in the telecommunications room, which prevents the risk of electrical shock.

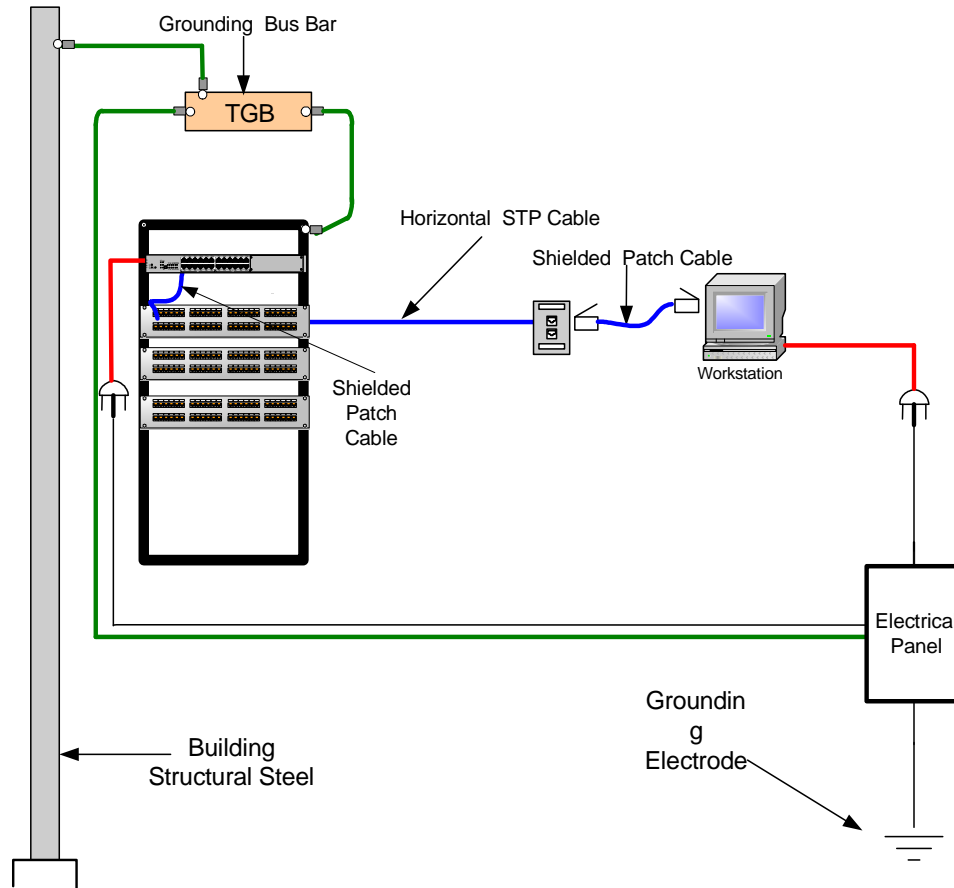
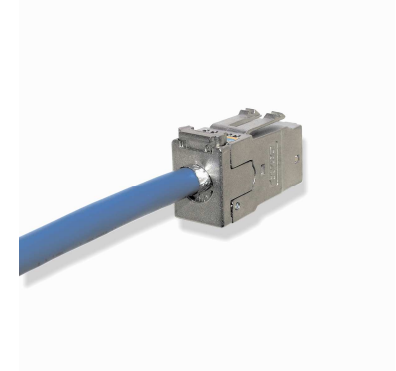

Figure 2: Bonding and Grounding at the Workstation

MAINTAINING CONTINUITY OF THE SHIELD FROM CABLE TO PLUG TO JACK

In an STP system, the shield should completely surround the cable along its entire length, and the shield should remain continuous along the entire length of the channel from the transmitter to receiver. This is accomplished by using only shielded products throughout the entire channel, from cable to plug to jack to patch panel.

Proper installation is also central to maintaining continuity of the shield. When terminating a shielded jack, the shield must make contact with the connector. With some of the newer technology in connecting hardware available today, ensuring that contact is quite simple. For example, Tyco Electronics' AMPTWIST shielded jacks are all metal and feature a spring-loaded cable strain relief that automatically provides a 360-degree contact to the terminated shield. In fact, the entire process of terminating an AMP NETCONNECT shielded jack to STP cable takes 60 seconds or less. Once the jack is properly terminated, simply placing the jack in the patch panel provides the electrical bond between the panel and the shield.



TESTING FOR GROUND LOOPS AND PROPER GROUNDING & BONDING

In an electrical system, a ground loop refers to an unwanted current that flows in a conductor connecting two points that are at different voltages. Another misconception surrounding shielded cable is that ground loops will always be a problem. However, ground loops that affect network performance can only occur when a system has more than one path to ground and the voltage difference between the two points are more than 1 Volt. If the components of a telecommunications system are properly bonded, and the system is effectively bonded to the building's grounding electrode system, there is virtually no condition where a ground loop is possible.

The only way to ensure proper grounding and bonding for either a UTP or STP system is to test upon completion. Ground potential difference should not exceed 1 Volt. Testing for ground potential difference can be done using an Earth Ground Resistance Tester with the entire building in operation. In other words, nothing needs to be shut down to test the grounding and bonding. Earth Ground Resistance Testers can be purchased pretty much anywhere telecommunications testers are sold.

It is imperative to test the potential difference between the TMGB and the electrical ground and between the TMGB and each TGB. Within the telecommunications space, testing should also be done between the TGB and all racks, cable tray, and electronic equipment. ANSI/TIA-568-C.0, *Generic Telecommunications Cabling for Customer Premises*, states in clause 5.3.5 that, "Equipment is usually grounded through the equipment power connection. The screen of screened twisted-pair (ScTP) cables shall be bonded to the telecommunications grounding busbar (TGB) or telecommunications main grounding busbar (TMGB). To extend the screen of Cabling Subsystem 1 [horizontal cabling] at the equipment outlet (EO) [workstation outlet] to the equipment, use an ScTP cord. Voltage of greater than 1.0 V_{rms} between the screen of Cabling Subsystem 1 at the EO and the ground wire of the corresponding electrical outlet expected to provide power to the equipment indicates improper grounding and is not recommended. The bonding and grounding infrastructure should be modified so that this voltage is less than 1.0 V_{rms}." What this statement is saying is that the difference in ground potential between the telecommunications and electrical system at the workstation should not exceed 1.0 volt.

Some may want to have their grounding and bonding system independently tested or certified by a qualified electrical contractor or engineer. Locating an independent grounding and bonding test engineer may be difficult, but if you do request a certified test, do your research and only use qualified consultants.

SUMMARY

In the past, little was known about properly grounding and bonding telecommunications systems. As a result, many problems occurred. Because the first generation of telecommunications cabling was shielded, many associated grounding and bonding issues with these systems. But times have changed. Grounding and bonding is now a science that qualified installers understand and practice, and STP cabling and components have evolved dramatically since the early days of inception. The problems associated with previous versions of shielded systems are no longer.

Proper grounding and bonding is a sizeable job whether it is UTP or STP, and there is virtually no difference in the requirements between the two. Yes, the shield must maintain continuity throughout a channel, but achieving that condition does not require any additional labor or technique. It's as simple as properly terminating the shielded jack and using shielded components throughout the channel. In today's IT world, it is VITAL for customers who rely so heavily on their communication system to ensure proper grounding and bonding – whether it's a UTP or STP system. For more information on grounding and bonding and installing an AMP NETCONNECT shielded cabling system, contact customer service at 1-800-553-0938. For more information on the TIA J-STD-607 Grounding and Bonding standard or the TIA/EIA-568C standards visit www.tiaonline.org.